

Bravo
LINE

*HTB21 helper a richiesta
Helper optional
Helper a petición
code 8-11900261

21"



HPA
Faip



Smontagomme automatico per autovetture, trasporto leggero, motoveicoli e scooter



Automatic tyre changer for cars, lightweight transport vehicles and motor vehicles



Desmontadora de neumáticos automática para vehículos, transporte ligero, motos y scooters

M 51

IT Dati tecnici	EN Technical data	ES Datos técnicos
------------------------	--------------------------	--------------------------

<input type="checkbox"/> Presa esterna	<i>Outside clamp</i>	Toma externa	10" - 21"
<input type="checkbox"/> Presa interna	<i>Inside clamp</i>	Toma interna	12" - 24"
<input type="checkbox"/> Diametro max. ruota	<i>Max. wheel diameter</i>	Diámetro máx. Rueda	1040 mm
<input type="checkbox"/> Larghezza pneumatico	<i>Tire width</i>	Ancho neumático	3" - 12"
<input type="checkbox"/> Apertura stallonatore	<i>Bead-breaker opening</i>	Apertura destalonador	320 mm
<input type="checkbox"/> Potenza stallonatura	<i>Bead-breaking power</i>	Potencia destalonado	1500 N
<input type="checkbox"/> Pressione di esercizio aria	<i>Working air pressure</i>	Presión de funcionamiento aire	8 - 10 bar
<input type="checkbox"/> Potenza motore (motore a due velocità con comando a pedale)	<i>Motor power (pedal control two speed motor)</i>	Potencia motor (motor de dos velocidades con mando de pedal)	0,75 kW - 1.1 kW
<input type="checkbox"/> Velocità rotazione mandrino	<i>Chuck rotation speed</i>	Velocidad rotación mandril	7 rpm - 2V 6.5 -13 rpm
<input type="checkbox"/> Rumorosità durante il funzionamento	<i>Noise level running</i>	Ruido durante el funcionamiento	<70 dB
<input type="checkbox"/> Peso netto macchina	<i>Nett weight machine</i>	Peso neto máquina	246 kg
<input type="checkbox"/> Peso lordo macchina	<i>Gross weight machine</i>	Peso bruto máquina	285 kg
<input type="checkbox"/> Dimensione max imballo (lpxh)	<i>Max dimension imballage (lpxh)</i>	Dimensión máx. embalaje (lpxh)	1130x910x1010 mm
<input type="checkbox"/> Per contenitore da 40"	<i>For 40" container</i>	Para contenedor de 40"	36 pcs

Dotazione - Equipment - Dotación



Dimensioni - Dimensions - Dimensiones

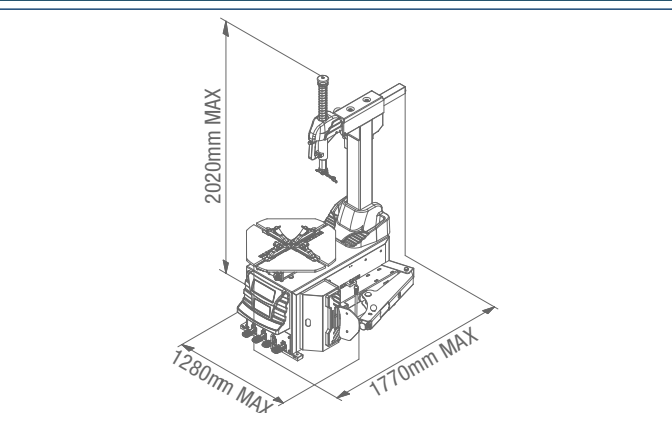

Accessori consigliati - Recommended accessories - Accesorios recomendados

CTS-0200000	CTS-0110000	C-TS-0310000
C-21-8000100	C-M-0200000A	C-TS-0600000
8-11900271	8-11900270	8-11120075

<p>CT-S-0200000</p> <ul style="list-style-type: none"> - Pinza premitallone in plastica - <i>Plastic bead pressing clamp</i> - Pinza prensa talón de plástico <p>CT-S-0110000</p> <ul style="list-style-type: none"> - Attrezzo per cambio rapido testina di smontaggio - <i>Demount head quick change tool</i> - Equipo para cambio rápido cabezal de desmontaje <p>CT-S-0310000</p> <ul style="list-style-type: none"> - Gruppo testina di smontaggio in plastica (per modelli a ribaltamento) - <i>Plastic demount head assy (for tilt back model use)</i> - Grupo cabezal de desmontaje de plástico (para modelos abatibles) <p>C-21-8000100</p> <ul style="list-style-type: none"> - Testina di smontaggio motocicletta - <i>Motorcycle demount head</i> - Cabezal de desmontaje motocicleta <p>C-M-0200000A</p> <ul style="list-style-type: none"> - Adattatore motocicletta (stile rullo manuale), per uso con sistema a griffe STANDARD - <i>Motorcycle adaptor (hand roller style), for STANDARD jaw system use</i> - Adaptador motocicleta (estilo rodillo manual), para uso con sistema de garras interno 	<p>CT-S-0600000</p> <ul style="list-style-type: none"> - Supporto rotazione ruota WRSB - <i>Wheel rotation support WRSB</i> - Soporte rotación rueda WRSB <p>8-11900271</p> <ul style="list-style-type: none"> - Kit protezioni in plastica leva e paletta - <i>Lever and shoe plastic protection kit</i> - Kit protecciones de plástico palanca y paleta <p>8-11900270</p> <ul style="list-style-type: none"> - Kit protezioni in plastica - <i>Plastic protection kit</i> - Kit protecciones de plástico <p>8-11120075</p> <ul style="list-style-type: none"> - Sollevatore ruota FWL 65 - <i>Wheel lifter FWL 65</i> - Elevador de ruedas FWL 65
--	---

Le immagini, le configurazioni e le caratteristiche tecniche riportate nel presente stampato hanno il solo scopo di presentare il prodotto e sono soggette a variazioni. Per una corretta definizione dell'ordine fare sempre riferimento al listino prezzi in vigore.
 The illustrations, configurations and technical features in this publication are intended to present the product only, and are subject to variation.
 To ensure correct ordering, always refer to the current price list.
 La única finalidad de todas la imágenes, configuraciones técnicas incluidas en el presente documento es la presentación del producto e, por tanto, están sujetas a variaciones. Para efectuar correctamente un pedido se deberá tomar siempre como referencia la lista de precios válida

